

8-bit REAL TIME CLOCK MODULE

RTC-64611/64613

- Built-in crystal unit allows adjustment-free efficient operation.
- 8-bit data bus and high speed access (85 ns Max.).
- Provided with the same interface as S-RAM and battery backup function.
- Interruption of alarm of sec. to day and day of week and carry interruption.
- Reference signal selectable in a range of 1 Hz to 64 Hz (binary).
- Leap year automatically adjustable (gregorian calendar).
- With 1 Hz output terminal.
- Provided with START/STOP, 30 second adjust function.
- RTC-64613 uses a similar mounting method to that of a normal SMD IC.

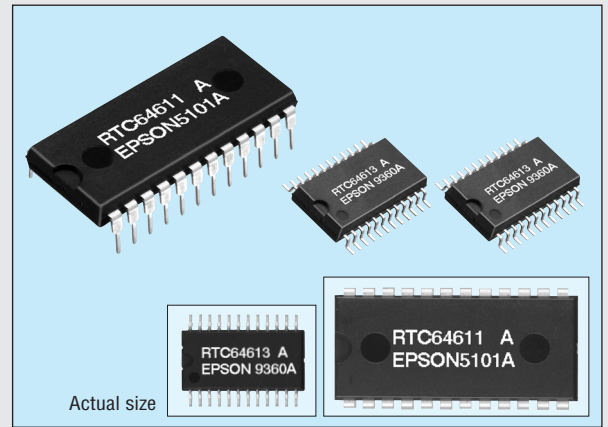

Specifications (characteristics)

Absolute Max. rating

Item	Symbol	Condition	Specifications	Unit
Power source voltage	V _{DD}	Ta=+25 °C	-0.5 to 7.0	V
Input voltage	V _{IN}		-0.5 to V _{DD} +0.3	
Storage temperature	T _{STG}	RTC-64611	-55 to +85	°C
		RTC-64613	-55 to +125	
Soldering condition	T _{SOL}	RTC-64611	Under +260 °C within 10 s (lead part) (package should be less than +150 °C)	
		RTC-64613	Twice at under +260 °C within 10 s or under +230 °C within 3 min.	

Operating range

Item	Symbol	Condition	Specifications	Unit
Operating voltage	V _{DD}	—	4.5 to 5.5	V
Operating temperature	T _{OPR}		-20 to +75	°C
Data holding voltage	V _{DH}	CS ≥ V _{DD} - 0.2 V	2.0 to 4.5	V
CS data holding time	t _{CDR}		0 Min.	ns
Operation restoring time	t _R		t _{RC} (85 ns)	

Frequency characteristics and current consumption characteristics

Item	Symbol	Condition	Specifications	Unit	
Frequency tolerance	Δf/fo	Ta=+25 °C	64611 A	+15/-5(5±10)	x 10 ⁻⁶
			64611 B	+55/-45(5±50)	
		V _{DD} =5 V	64613 A	+25/-15(5±20)	
			64613	+55/-45(5±50)	
Frequency temperature characteristics		-10 to +70 °C (+25 °C reference temperature)	+10/-120		
		-20 to +75 °C (+25 °C reference temperature)	+10/-220		
Aging	fa	V _{DD} =5 V, Ta=+25 °C, first year	±5 Max.	x 10 ³ /year	
Shock resistance	S.R.	Three drops on a hard board from 750 mm or 29400 m/s ² x 0.3 ms x 1/2 sine wave x 3 directions	±10 Max.	x 10 ⁻⁶	
Current consumption	I _{DD1}	No load V _{DD} =5 V	2 Max.	mA	
	I _{DD2}	CS ≥ 1.8 V V _{DD} =2 V		μA	

Unless otherwise stated, characteristics (specifications) shown in the above table are based on the rated operating temperature and voltage condition.

DC characteristics

(Ta = -20 to +75 °C)

Item	Symbol	Condition	V _{DD} =5 V ±10 %		V _{DD} =2 V		Unit
			Min.	Max.	Min.	Max.	
"H" input voltage	V _{IH}		2.2	V _{DD}	V _{DD} -0.2	V _{DD}	V
"L" input voltage	V _{IL}		-0.3	0.8	-0.3	0.2	
Input leak current	I _{IN}			±2		±2	μA
Three-state leak current	I _{TSL}					±10	
Output leak current	I _{LOH}					±10	
"H" output voltage (except for 1 Hz, I _{RD})	V _{OH}	I _{OH} =-1 mA	2.4	—	—	—	V
"L" output voltage	V _{OL}	I _{OL} =2.1 mA		0.4		—	
Input capacity	C _{IN}	V _{IN} =0 V Ta=+25 °C		12.5			pF
Output capacity	C _{OUT}	f=1.0 MHz					

Terminal connection

No.	Pin terminal	No.	Pin terminal
1	GND	13	I/O _s
2	H-START/STOP	14	I/O _s
3	I _{RD}	15	I/O _s
4	1Hz	16	I/O _s
5	A ₃	17	I/O _s
6	A ₂	18	CS
7	A ₁	19	OE
8	A ₀	20	WE
9	I/O ₁	21	NC
10	I/O ₂	22	(V _{DD})
11	I/O ₃	23	(V _{DD})
12	GND	24	V _{DD}

• (V_{DD}) is to be same level as V_{DD}. Do not connect it to any external terminals.
• NC is not connected internally.

External dimensions

(Unit: mm)

• RTC-64611

• RTC-64613

Register table

Address	Data								Remarks	
	b ₇	b ₆	b ₅	b ₄	b ₃	b ₂	b ₁	b ₀		
0		1 Hz	2 Hz	4 Hz	8 Hz	16 Hz	32 Hz	64 Hz	Counter	
1	*	10-sec. digit			1-sec. digit					
2		10-min. digit			1-min. digit					
3	*	10-hour digit			1-hour digit					
4		*			Day-of-week digit					
5	*	10-day digit			1-day digit					
6		*			10-month digit	1-month digit				
7		10-year digit			1-year digit					
8	ENB	1 Hz	2 Hz	4 Hz	8 Hz	16 Hz	32 Hz	64 Hz	Alarm register	
9		10-sec. digit			1-sec. digit					
A		10-min. digit			1-min. digit					
B		*	10-hour digit			1-hour digit				
C		*			Day-of-week digit					
D	*	10-day digit			1-day digit					
E	Carry flag	*		Carry interruption enable	Alarm interruption enable	*		Alarm flag	Control register	
F	RAM7	RAM6	RAM5	RAM4	TEST ^{*1}	30-sec. adjustment	RESET	S.START /STOP		

*1 Be sure to enter "0" to TEST bit.

Supplement

Bit name	Description
* mark	Empty bit and unwritable Recognized as "0" while reading
10-hour digit (b ₅)	Only for 24 h mode
Under-sec. counter	Read only (unwritable) Used as binary code data
Under-sec. alarm register	Used as binary code data
Sec.to year	Both counter and alarm register use BCD code
Day of week	Coded data is used EX: 0...Sunday 1...Monday 2...Tuesday 3...Wednesday 4...Thursday 5...Friday 6...Saturday

Note: Do not enter erroneous data for clock. This may result in time keeping error.

Block diagram

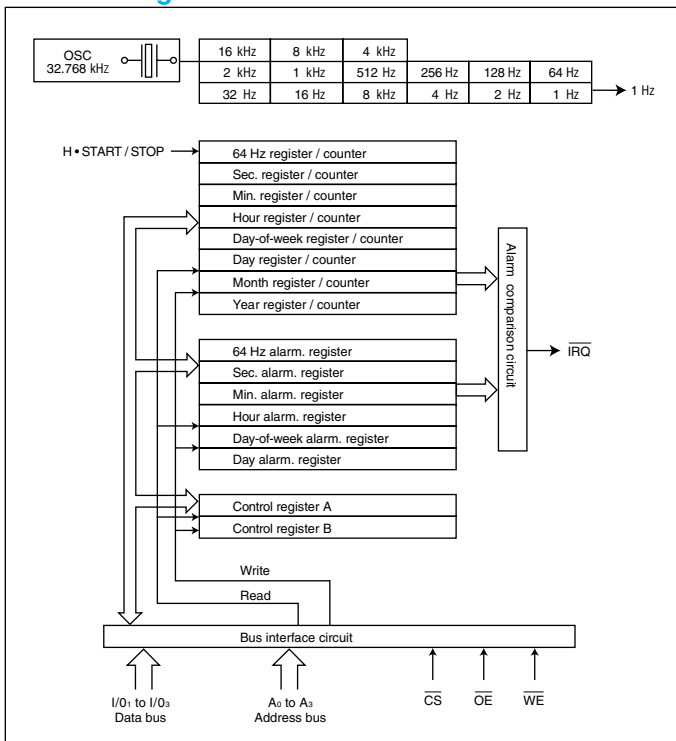

Switching characteristic

Measuring condition

- Input pulse level: 0.8 to 2.4 V
- Input rise time, fall time: 5 ns
- IN/OUT timing pulse level: 1.5 V
- Out put load: 1 TTL Gate +100 pF

Read mode

Item	Symbol	Min.	Max.	Unit
Read cycle time	t _{RC}	85	—	ns
Address access time	t _{AA}	—	85	
Chip select access time	t _{ACS}	—	—	
Output enable access time	t _{OE}	—	45	
Output hold time	t _{OH}	10	—	
Chip select / output set time	t _{CLZ}	—	—	
Output enable / output set time	t _{OLZ}	5	—	
Chip deselect / output floating	t _{CHZ}	0	35	
Output disable / output floating	t _{OHZ}	0	35	

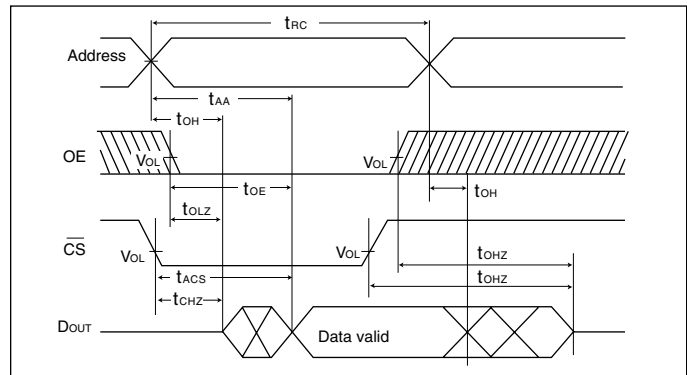

Write mode

Item	Symbol	Min.	Max.	Unit
Write cycle time	t _{WC}	85	—	ns
Chip select time	t _{CW}	75	—	
Address valid time	t _{AW}	—	—	
Address setup time	t _{AS}	0	—	
Write pulse time	t _{WP}	60	—	
Address holding time	t _{WR}	10	—	
WE output floating	t _{WHZ}	0	35	
Input data set time	t _{DW}	40	—	
Input data hold time	t _{DH}	0	—	
Output disable / output floating	t _{OHZ}	0	35	
WE output set time	t _{OW}	5	—	

